



Pick Up & Count Vacuum™



Parent's Guide

This guide contains important information. Please keep it for future reference.

91-003833-000 (US)

INTRODUCTION

Thank you for purchasing the **Pick Up & Count Vacuum™**.

This smart vacuum recognizes the dust pieces it picks up to teach numbers, counting and colors while promoting imaginary play in three different modes. The six games reinforce learning with play. Pushing the vacuum around to pick up the ten dust pieces promotes the development of gross motor skills.

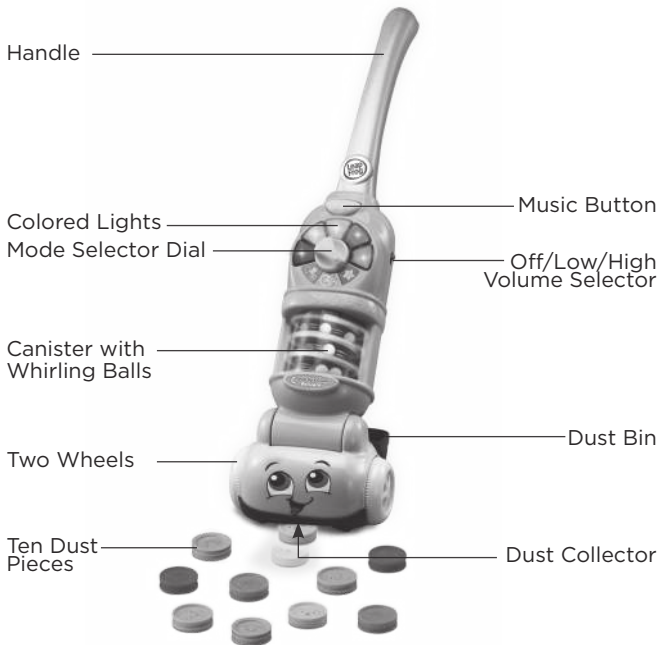

INCLUDED IN THIS PACKAGE

- **Pick Up & Count Vacuum™**
- 2 Red Dust Pieces
- 2 Orange Dust Pieces
- 2 Yellow Dust Pieces
- 2 Green Dust Pieces
- 2 Blue Dust Pieces
- Parent's guide

WARNING

All packing materials such as tape, plastic sheets, packaging locks, removable tags, cable ties and packaging screws are not part of this toy, and should be discarded for your child's safety.

NOTE

Please keep this parent's guide as it contains important information.

ATTENTION

Pour la sécurité de votre enfant, débarrassez-vous de tous les produits d'emballage tels que rubans adhésifs, feuilles de plastique, attaches, étiquettes et vis d'emballage. Ils ne font pas partie du jouet.

NOTE

Il est conseillé de conserver ce guide des parents car il comporte des informations importantes.

Unlock the Packaging Locks

- ① Turn the packaging lock counterclockwise several times.
- ② Pull out the packaging lock and discard.

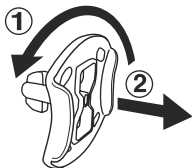

GETTING STARTED

BATTERY REMOVAL AND INSTALLATION

1. Make sure the unit is turned **Off**.
2. Find the battery cover located on the bottom of the unit and use a screwdriver to loosen the screw and open the battery cover.
3. Remove old batteries by pulling up on one end of each battery.
4. Install 4 new AA (AM-3/LR6) batteries following the diagram inside the battery box.
5. Replace the battery cover and tighten the screw to secure.

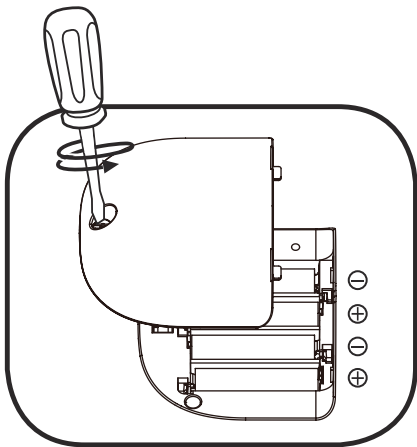

BATTERY NOTICE

- Use new alkaline batteries for maximum performance.
- Use only batteries of the same or equivalent type as recommended.
- Do not mix different types of batteries: alkaline, standard (carbon-zinc) or rechargeable, or new and used batteries.
- Do not use damaged batteries.
- Insert batteries with the correct polarity (+ and -).
- Do not short-circuit the battery terminals.
- Remove exhausted batteries from the toy.
- Remove batteries during long periods of non-use.
- Do not dispose of batteries in fire.
- Do not charge non-rechargeable batteries.
- Remove rechargeable batteries from the toy before charging (if removable).
- Rechargeable batteries are only to be charged under adult supervision.

MISE EN GARDE

- Utiliser des piles alcalines neuves pour des performances maximales.
- Seules des piles du type recommandé doivent être utilisées.
- Ne pas mélanger différents types de piles ou d'accumulateurs, ne pas mélanger des piles ou des accumulateurs neufs avec des usagés.
- Ne pas utiliser des piles ou des accumulateurs endommagés.
- Mettre en place les piles ou les accumulateurs en respectant les polarités + et -.
- Ne pas mettre les bornes d'une pile ou d'un accumulateur en court-circuit (en reliant directement le + et le -).
- Enlever les piles ou les accumulateurs usagés du jouet.
- Retirer les piles ou les accumulateurs en cas de non-utilisation prolongée.
- Ne les jeter ni au feu ni dans la nature.
- Ne pas tenter de recharger des piles non rechargeables.
- Enlever les accumulateurs du jouet pour les recharger.
- Les accumulateurs ne doivent être chargés que sous la surveillance d'un adulte.

ASSEMBLY

With the **Pick Up & Count Vacuum™** safety comes first. Adult assembly is required. For your child's safety, do not let them play with this toy until it is fully assembled.

1. Slide the **Off/Low/High Volume Selector** to the **Off** position.

2. Insert the handle into the top of the vacuum body. After the handle is assembled, it cannot be disassembled. Slide the **Off/Low/High Volume Selector** to the Low or High positions to turn the unit **On** in Normal Play mode.

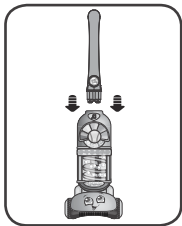

NOTE

If the handle is not inserted into the vacuum body, the toy will remain in Demo mode.

NOTE



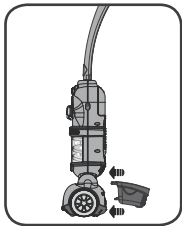

This toy is intended for steady walkers and is not a learn-to-walk toy.

3. Attach the **Dust Bin** to the back of the vacuum base. For safety reasons, the **Dust Bin** will detach from the vacuum base if significant force is applied. If the **Dust Bin** detaches unintentionally, simply reattach it to the vacuum base.



PRODUCT FEATURES

1. Off/Low/High Volume Selector

To turn the unit **On**, slide the **Off/Low/High Volume Selector** from the **Off**  position to the **Low**  or **High**  position. To turn the unit **Off**, slide the **Off/Low/High Volume Selector** to the **Off**  position.



2. Mode Selector Dial

Turn to choose between three ways to play:



Number Mode

Listen to the **Vacuum's** instructions for picking up **Dust Pieces** to play three games that promote number identification, counting 1-10 and early subtraction.

Color Mode

Listen to the **Vacuum's** instructions for picking up **Dust Pieces** to play three games that promote naming, identifying and matching colors.

Pretend Play Mode

Pick up **Dust Pieces** to hear vacuuming sounds and fun **Dust Pieces'** voices while playing cleanup.

3. Handle, Wheels, Dust Collector and Dust Bin

With the wheels and tilting **Handle**, the **Vacuum** is easy to maneuver into position to roll over a **Dust Piece** which picks it up through the **Dust Collector**. The **Vacuum** then deposits the **Dust Piece** inside the **Dust Bin**.



NOTE

If a **Dust Piece** is stuck inside the vacuum channel, gently roll the **Vacuum** forward to move the **Dust Piece** into the **Dust Bin**.

4. Five Colored Lights & Whirling Balls

The five **Colored Lights** light up to count along or match the color of the **Dust Piece** collected as well as provide color cues and game instruction. When a **Dust Piece** is picked up or a game ends, the five **Colored Lights** animate while the canister spins with **Whirling Balls** as a reward.



5. Music Button

Press the **Music Button** to hear three songs about counting numbers from 1-10, colors and cleaning up.



6. Automatic Shut-Off

To preserve battery life, the **Pick Up & Count Vacuum™** will automatically shut off after approximately 75 seconds without input. The unit can be turned on again by pressing the **Music Button**, turning the **Mode Selector Dial** or picking up a **Dust Piece** with the **Vacuum**.

NOTE

If the unit powers down or if the lights fade out during play, please install a new set of batteries.

NOTE

Do not place any object into the vacuum's **Dust Collector** other than the **Dust Pieces** provided with the **Pick Up & Count Vacuum™**.

NOTE

The unit works when rolling on flat, hard surfaces but works best when rolling on low to medium pile carpets and rugs.

NOTE

This toy does not provide a stable base for maintaining balance and should not be used by children who are unable to walk independently.

ACTIVITIES

1. Number and Counting Play

Number mode offers three games to play:

- **Clean and Count:** The **Vacuum** counts along 1-10, announces the number of **Dust Pieces** collected and rewards the total number collected.
- **Pick-Pick-Pick 'Em Up:** The **Vacuum** prompts the child to pick up a specific number of **Dust Pieces**. It counts along with each **Dust Piece** collected and announces how many pieces are remaining for early exposure to subtraction.
- **Final Countdown:** The **Vacuum** asks the child to collect as many **Dust Pieces** as possible before the timer runs out.

2. Color Play

Color mode offers three games to play:

- **Color Callout:** After picking up a **Dust Piece**, the **Vacuum** announces its color and relates the color to a food or animal.
- **Light & Seek:** The **Vacuum** blinks one of the five **Colored Lights** and prompts the child to find and pick up the matching colored **Dust Piece** to reinforce color recognition and matching.

- **Catch the Rainbow:** The **Vacuum** prompts the child to collect one **Dust Piece** for each of the five colors.

3. Pretend Play

In Pretend Play mode, pretend to clean up with the **Vacuum** by rolling it back and forth to pick up the **Dust Pieces** and hear their unique and fun responses along with vacuuming sounds.

4. Musical Play

Press the **Music Button** to listen and dance along to three songs.

SONG LYRICS

Cleaning Up Song

The rug is kind of dusty
So let's get out our trusty
Vacuum and run it all around the floor
Cleaning up, having fun
Let's do it some more.

Counting 1-10 Song

Picking up
Picking up
It's dusty as can be
1, 2, 3
4, 5, 6
7, 8
9 and 10
The floor is now quite spic 'n span
For everyone to see.

Colors Song

Yellow says hello
Green is keen
Orange is a color
Rhyme has never seen
Red is what I said, and
Blue is fun for you

CARE & MAINTENANCE

1. Keep the unit clean by wiping it with a slightly damp cloth.
2. Keep the unit out of direct sunlight and away from any direct heat sources.
3. Remove the batteries if the unit will not be in use for an extended period of time.
4. Do not drop the unit on hard surfaces and do not expose the unit to moisture or water.

TROUBLESHOOTING

If for some reason the program or activity stops working, please follow these steps:

1. Turn the unit **Off**.
2. Interrupt the power supply by removing the batteries.
3. Let the unit stand for a few minutes, then replace the batteries.
4. Turn the unit back **On**. The unit should now be ready to use again.
5. If the unit still does not work, install a new set of batteries.

Environmental Phenomena

The unit may malfunction if subjected to radio-frequency interference. It should revert to normal operation when the interference stops. If not, it may become necessary to turn the power **Off** and back **On**, or remove and reinstall the batteries. In the unlikely event of an electrostatic discharge, the unit may malfunction and lose memory, requiring the user to reset the device by removing and reinstalling the batteries.

Impact de l'environnement

Une défaillance de fonctionnement de l'appareil peut survenir s'il est sujet à des interférences avec les fréquences radioélectriques. Le fonctionnement normal de l'appareil devrait reprendre avec l'arrêt des interférences. Si ce n'est pas le cas, il peut s'avérer nécessaire d'éteindre et rallumer l'appareil ou de retirer et réinstaller les piles. Dans l'éventualité peu probable d'une décharge électrostatique, un mauvais fonctionnement et une perte de mémoire de l'appareil peuvent se produire. L'utilisateur doit alors retirer et réinstaller les piles pour réinitialiser l'appareil.

IMPORTANT NOTE:

If the problem persists, please call our **Consumer Services Department** at **1-800-701-5327** in the U.S. or email **support@leapfrog.com**. Creating and developing LeapFrog® products is accompanied by a responsibility that we take very seriously. We make every effort to ensure the accuracy of the information, which forms the value of our products. However, errors sometimes can occur. It is important for you to know that we stand behind our products and encourage you to contact us with any problems and/or suggestions you might have. A service representative will be happy to help you.

NOTE

This equipment has been tested and found to comply with the limits for a Class B digital device, pursuant to Part 15 of the FCC Rules. These limits are designed to provide reasonable protection against harmful interference in a residential installation. This equipment generates, uses and can radiate radio frequency energy and, if not installed and used in accordance with the instructions, may cause harmful interference to radio communications. However, there is no guarantee that interference will not occur in a particular installation. If this equipment does cause harmful interference to radio or television reception, which can be determined by turning the equipment off and on, the user is encouraged to try to correct the interference by one or more of the following measures:

- Reorient or relocate the receiving antenna.
- Increase the separation between the equipment and receiver.
- Connect the equipment into an outlet on a circuit different from that to which the receiver is connected.
- Consult the dealer or an experienced radio/TV technician for help.

CAUTION

Changes or modifications not expressly approved by the party responsible for compliance could void the user's authority to operate the equipment.

**Supplier's Declaration of Conformity
47 CFR § 2.1077 Compliance Information**

Trade Name: LeapFrog®
Model: 6110
Product Name: **Pick Up & Count Vacuum™**
Responsible Party: LeapFrog Enterprises, Inc.
Address: 6401 Hollis Street, Suite 100,
Emeryville, CA 94608
Website: leapfrog.com

THIS DEVICE COMPLIES WITH PART 15 OF THE FCC RULES. OPERATION IS SUBJECT TO THE FOLLOWING TWO CONDITIONS: (1) THIS DEVICE MAY NOT CAUSE HARMFUL INTERFERENCE, AND (2) THIS DEVICE MUST ACCEPT ANY INTERFERENCE RECEIVED, INCLUDING INTERFERENCE THAT MAY CAUSE UNDESIREED OPERATION.

CAN ICES-3 (B)/NMB-3(B)

**CLASS 1
LED PRODUCT**

***Read our complete warranty policy online
at leapfrog.com/warranty***

LeapFrog Enterprises, Inc.,
A subsidiary of VTech Holdings Limited.
TM & © 2020 LeapFrog Enterprises, Inc.
All rights reserved.



*Visit our website for more
information about our products,
downloads, resources and more.*

leapfrog.com